



INTRODUCING

The new MANTSINEN 90



40% MORE
LIFTING POWER

CONTROL SYSTEM
REIMAGINED

AI & AUTOMATION
READY

FUTURE-PROOFED
SAFETY

Next generation performance.

The redesigned Mantsinen 90 builds on the proven strengths of earlier generations while introducing a stronger structure and smarter solutions that increase lifting capacity and durability.

The new future-proofed GEN3 control system and upgraded user interface provide a clear, intuitive operating experience for efficient work in demanding environments.

A renewed design with service walkways, modular construction and improved access points simplifies maintenance, enhances safety and maximizes uptime.

Stronger.

Significantly improved lifting capacity: +40%.

- High-quality design and production ensure durability in all conditions.

Smarter.

The new GEN3 control system offers a range of advanced features designed to improve operator comfort, usability, and connectivity.

- New touchscreen and graphical user interface.
- Latest generation of ergonomic joysticks.
- Interactive keypads for intuitive operation.
- Operator-specific settings for customized control.
- Over-The-Air(OTA) software updates.

Safer.

Advanced control functions improve performance, accuracy and operational safety.

- Improved power control.
- Integrated load control for smoother and more precise operation.
- High control accuracy and fast response.
- Improved Safety Features.*



* EN 13849-1:2023 safety functions. Movements at PLC and Emergency stop at PLD.



Lifting capacity

Lifting capacity range with 15 m curved main boom and 12 m stick.

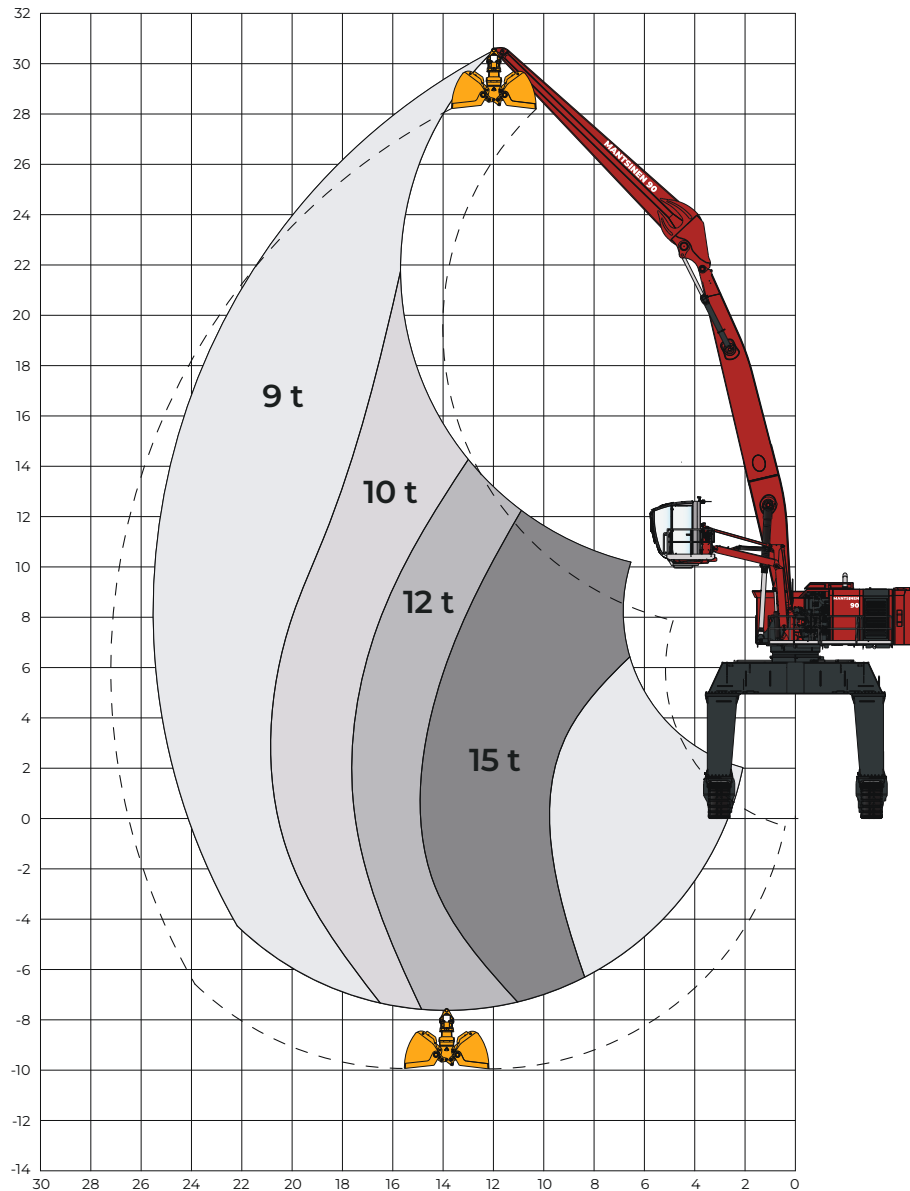

Technical specification

GENERAL	
Max reach	28 m
Approximate capacity	800 t/h
FRONT EQUIPMENT	
Main boom, straight or curved	10 / 11 / 12 / 13 / 14 / 15 m
Stick	8 / 9 / 10 / 11 / 12 / 13 m
POWER UNIT	
Diesel	285kW / 388 HP Stage V
Electric	235kW / 320 HP 50/60 Hz
HYDRAULIC SYSTEM	
HybriLift® energy recovery	Equivalent to 153 kW engine power
Oil flow, front equipment and travel	2 × 420 l/min
Operating pressure, front equipment	330 bar
Operating pressure, travel and Heavy Lift mode	350 bar
Oil flow, swing	410 l/min, closed loop system
Operating pressure swing	270 bar
Max swing speed	5.6 r/min
Swing torque	240 kNm

Crane classification according to EN 13001-1; Total duration of use U8; Over 2 million cycles. The applied load spectrum class Q5; The highest class. Calculated at maximum nominal load.



The strongest link in the global logistics chain.

Mantsinen provides more efficiency, speed and capacity for our global logistics chain customers, operating with heavy and basic industry raw materials and semi-finished products. We are the hands-on frontrunner in material handling.

Mantsinen Group Ltd Oy

Välikankaantie 3, 80400 Ylämylly, Finland

mantsinen.com

