

Options sheet		
Model number	Standard configuration	Optional configuration
Safety class	Rotating warning light	Battery built-in fire extinguishing system
	Turn signal light	Centralized fire fighting system
	Reverse buzzer	-
	Visual reverse radar	-
	Identification module meeting TSG 81	-
	Tilt oil circuit self-locking valve	-
	Lift oil circuit self-locking valve	-
Mast / attachments	4m mast	-
	Side shift fork positioner	-
	-	Whole vehicle lifting spreader
	-	Full free mast boom
Comfort Class	Grammer full suspension seats	boom
	Full hydraulic power steering	Fork arm extension
	USB charging port	-
	Radio	-
Tires	Patterned durable pneumatic tires	Full solid tires
	-	Front solid tires / inflatable rear tires
	-	Inflatable front tires / rear solid tires
Else	Patterned durable pneumatic tires	Centralized lubrication system
	Electric tilting cab	Weighing system
	Truck accompanying tools	-
	Truck networking terminal	-
	Double gun charging port	-
	Fixed/variable hydraulic system	-
	Hydraulic circuit oil filter	-
Wet brake	-	

Attachments options	
	<p>▪ <b>Side shift forks (standard)</b></p> <p>It has the functions of fork positioners and side shift to improve the working efficiency</p>
	<p>▪ <b>Fork arm extension</b></p> <p>Effective extension of fork, suitable for larger shape cargo handling</p>
	<p>▪ <b>Boom</b></p> <p>Suitable for goods in coils of steel, wire, etc</p>
	<p>▪ <b>Arm</b></p> <p>Lifting cargo safely and efficiently</p>
	<p>▪ <b>Pipe and wire spreader</b></p> <p>Suitable for the lifting of bundles of steel bars, steel pipes and other goods</p>

# 20-35 t

## G2 series Lithium Battery Counterbalance Forklift Truck

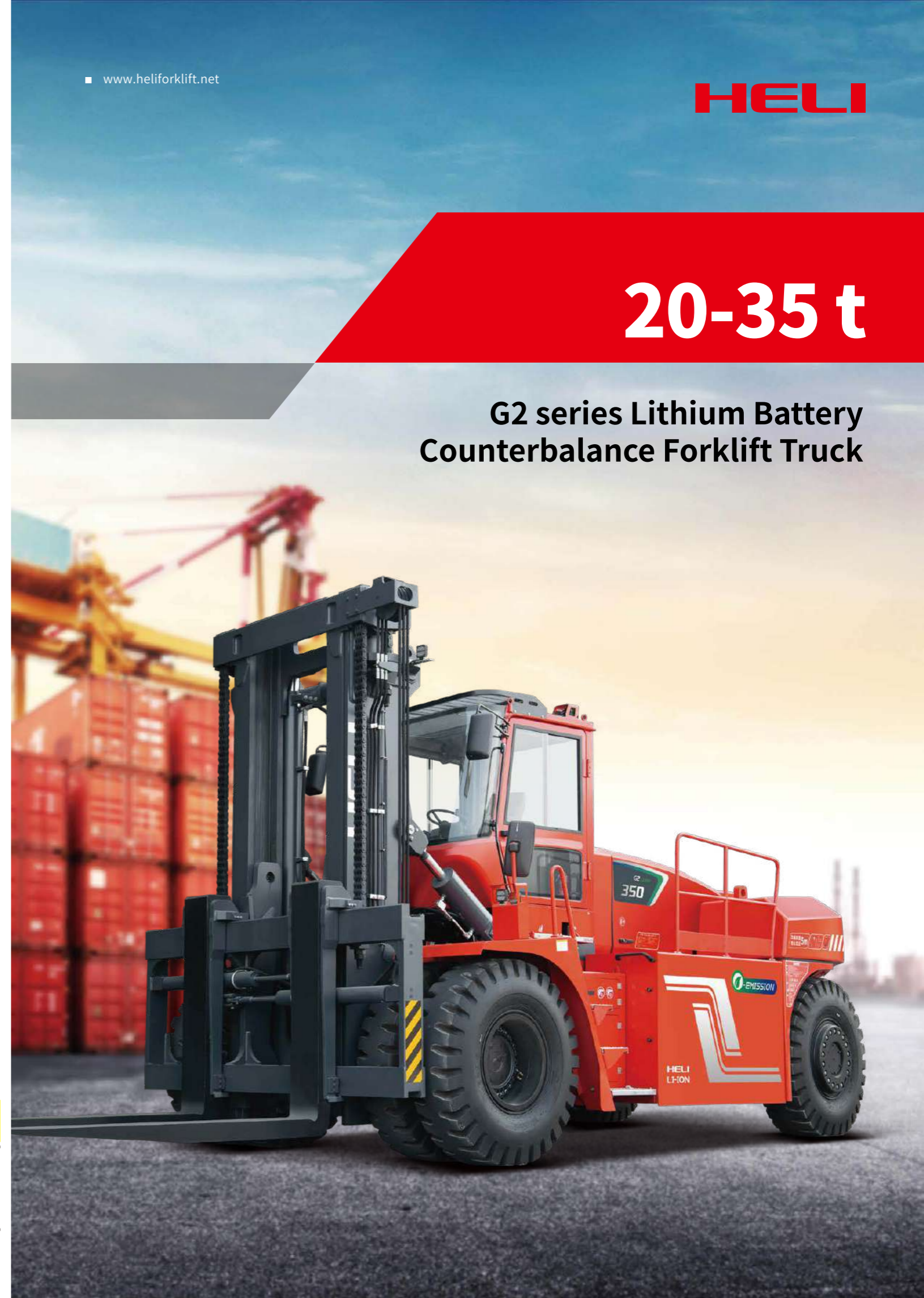

**ANHUI HELI CO., LTD.**

Add / No.668, FangXing Road, Hefei, China

Fax / +86-551-63639966

Tel / +86-551-63639068 (North America); 63634335 (Latin America);

63639258 (Europe); 63639358 (Asia); 63662105 (Africa& Middle East);

63648352 (Eurasia); 63629143 (Oceania);

E-mail / heli@heliforklift.net



LinkedIn



YouTube



Facebook

*With more than 60 years  
of Heli technical precipitation*

strengths of others and creates  
high-quality products.



Heli 20-35 tons electric forklift can be widely used in enterprises, stations, ports, docks, cabins and other places, for handling overweight, oversized cargo and handling and stacking some models of empty container.

# CHARACTERISTIC



## A MATURE PLATFORM

THE PLATFORM ENSURES TRUCK RELIABILITY AND DURABILITY.

With more than 60 years of efforts, Heli never stop

With good component development ability, the truck has good quality with exquisite design details.

The standardize platform design ensures high degree of universality.

Heavy truck lithium models uses mature platform, the standardization rate of the truck is more than 55%, and the standardization coefficient is more than 90%; Heli homemade integrated with battery box and batteries which can be applied in different tons of six kinds of models, effectively reduce numbers of spare parts and management costs.

## B STRONG PERFORMANCE

UP TO 40% BETTER PERFORMANCE THAN TRADITIONAL INTERNAL COMBUSTION TRUCKS

- The performance is equal to or even better than the mainstream internal combustion heavy truck, and the work efficiency is high.

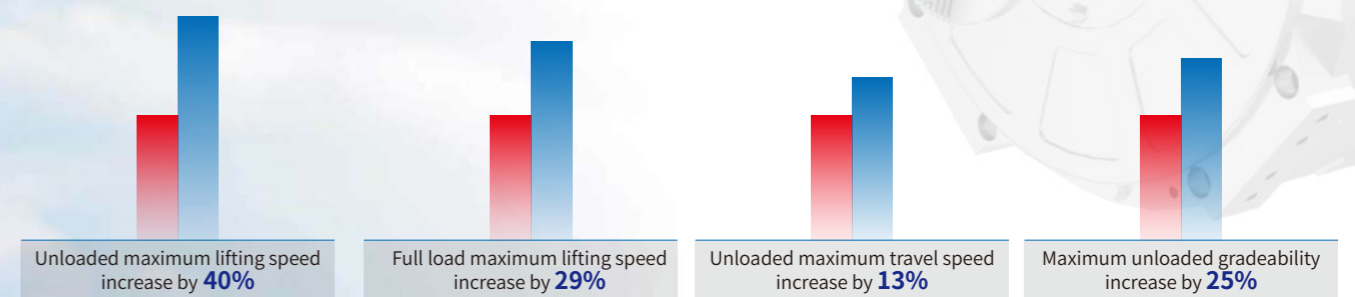

- The permanent magnet synchronous motor has the advantages of high working efficiency, fast response speed, low failure rate and good energy saving effect.
- The motor and electric control are cooled by water cooling to ensure its superior working condition.



- The truck is equipped with heavy truck special high-speed drive axle and wet brake which offer the features of dust proof, water proof and maintenance-free; Excellent braking performance meets the requirements of long time heavy working conditions; High axle housing strength ensures improved transfer efficiency and reliable performance;
- The hydraulic system has potential energy recovery function; The hydraulic system has excellent performance, good handling performance, high accuracy, and the truck is stable and reliable.

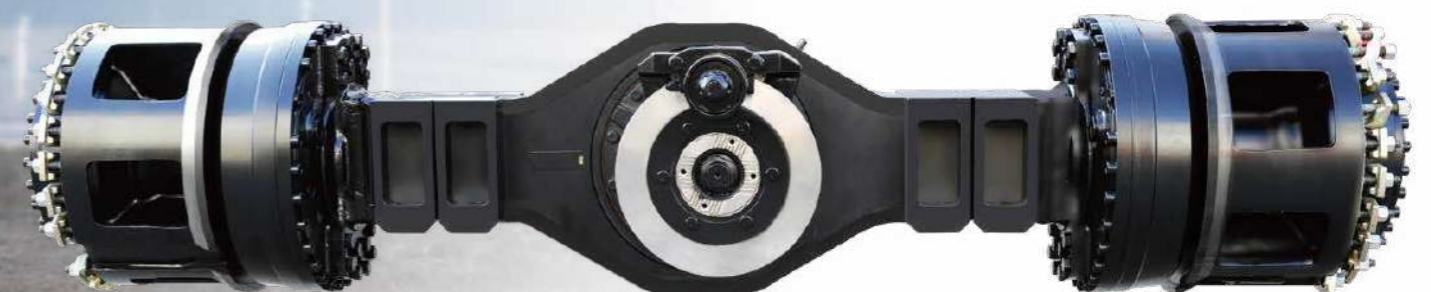

# C

## LONG BATTERY ENDUREANCE

THE CHARGING PORT IS COMPATIBLE WITH NEW ENERGY TRUCK CHARGING PILE

According to customer needs, the maximum 315kWh lithium battery can be optional. And with 1-1.5 hours double gun charging, the truck can meet the normal working conditions for about 10 hours.

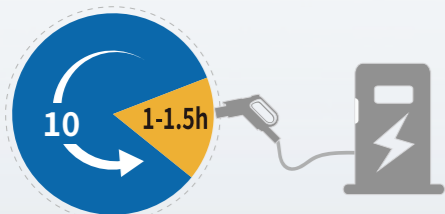

# D

## SMART SECURITY

EIGHT ASPECTS OF SECURITY

- The truck high voltage line has insulation online monitoring function, combined with intelligent fire protection system, real-time monitoring of truck status can be achieved;
- High protection level (IP67) high voltage electrical components and intelligent temperature management system meet the outdoor all-weather work needs.

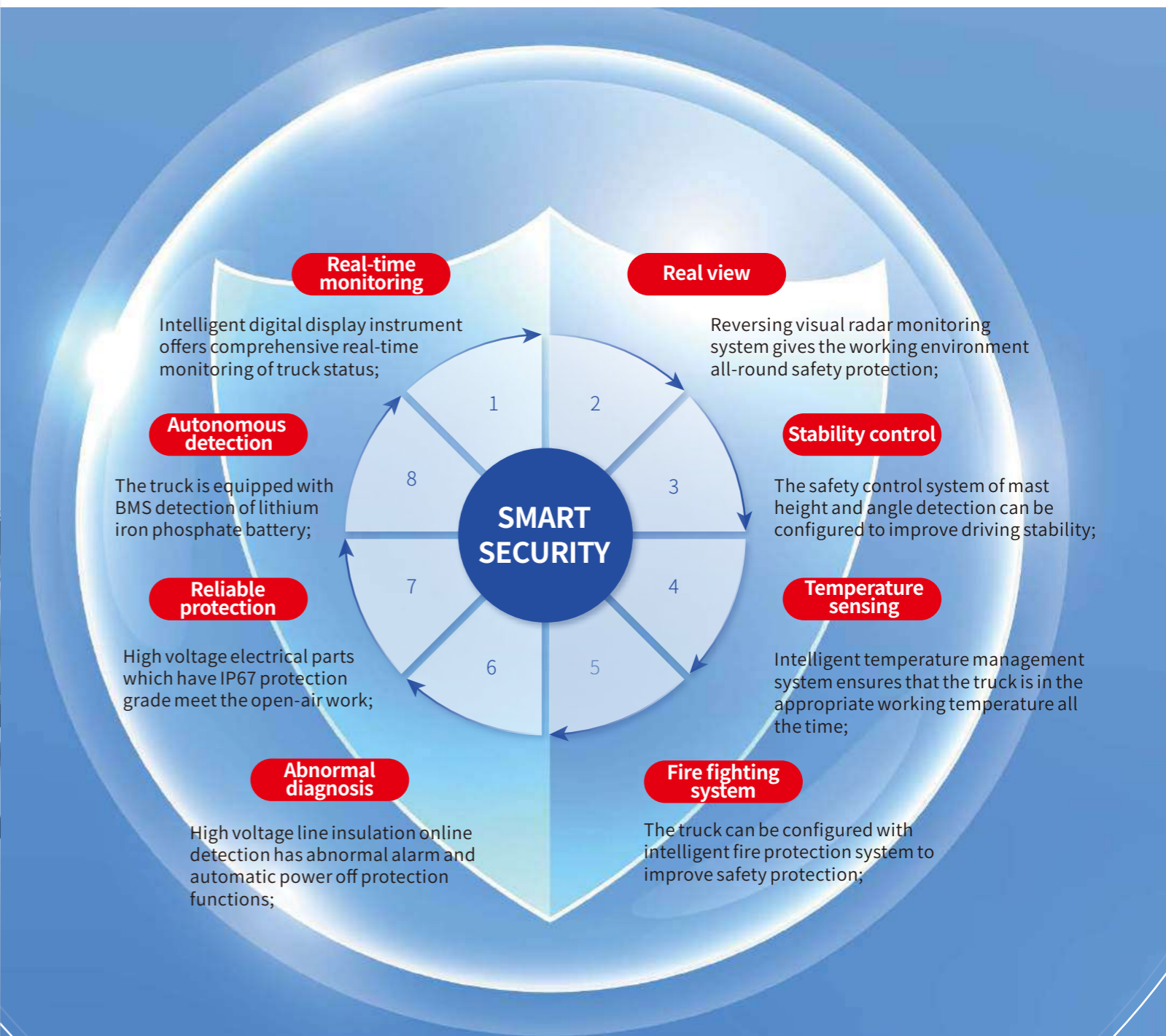

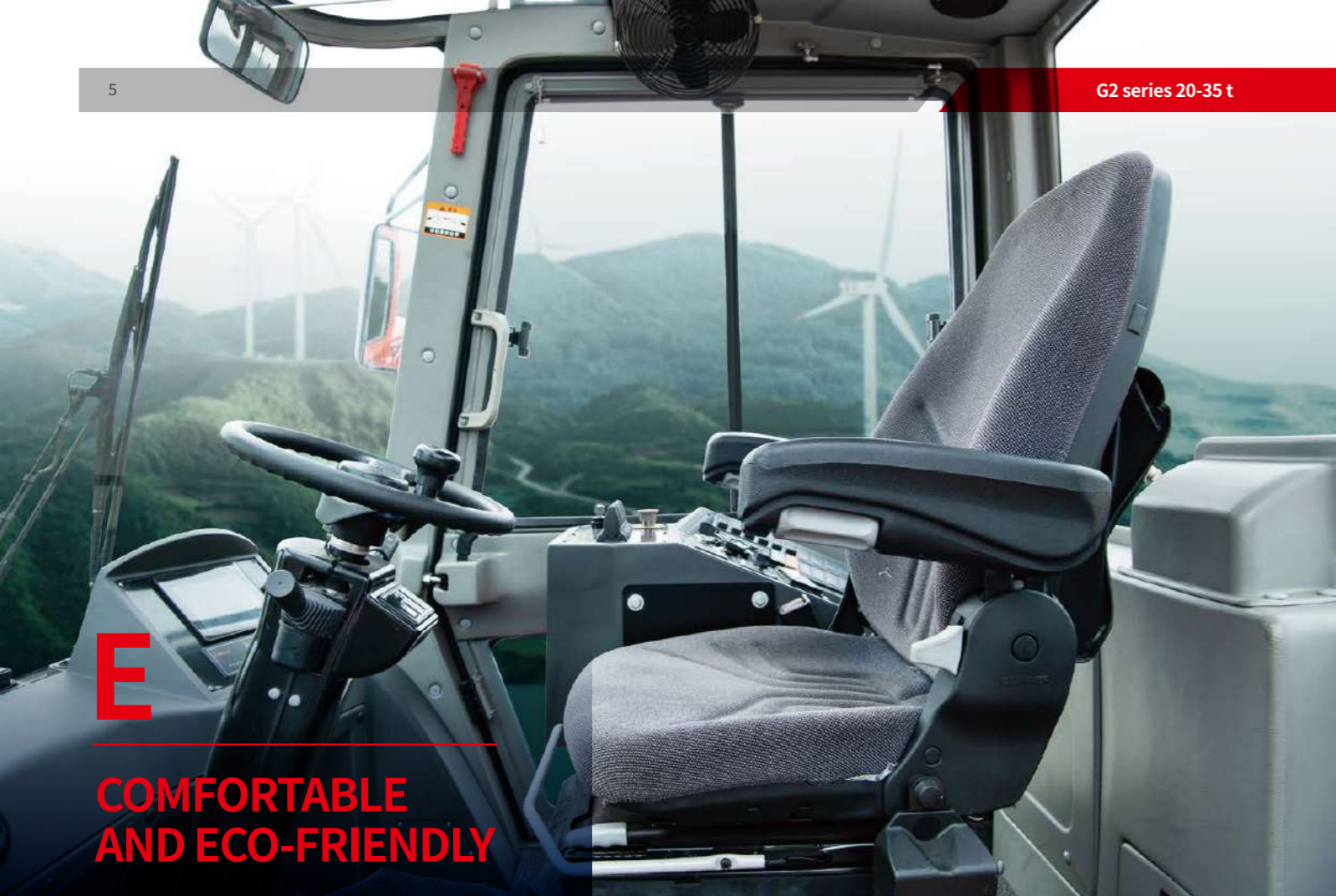

# E

## COMFORTABLE AND ECO-FRIENDLY

### A RELAXED DRIVING EXPERIENCE FOR CUSTOMERS



- Vibration reduction: the use of full suspension knitted surface seat greatly improves the ride comfort.
  - Noise reduction: fully closed electric tilting cab reduces the noise transmission of the whole machine.
  - Wide vision mast offers good operating vision; Standard rear working light makes work easy at night.
  - Rich instrument display content and human-computer interaction interface achieves timely acquisition of truck status, ensuring safe driving, stable operation.
  - Full hydraulic power steering make operation light and flexible.
  - Standard configuration of heating and cooling dual high-pressure electric split air conditioning offers high air conditioning energy utilization. The air duct is the front and the lower part, giving the driver a comfortable operating environment.
  - The action of the mast is controlled by the thumb switch, which makes the operation more light.
- 
- Low noise when the truck runs reduces noise pollution.
  - Pure electric operation achieve "zero emissions".

# F

## EASY MAINTENANCE

The comprehensive use cost is only 20% of the internal combustion forklift.

- Large tilting cab opening angle offers sufficient maintenance space;
- The new oil tank built-in suction filter offers convenient filter element replacement;
- Heli homemade integrated battery box with closed box and the plug-in sockets make the production, use and maintenance safer;
- Different ton models can share the same battery which effectively reduce numbers spare parts and management costs.



- The truck is equipped with potential energy recovery and kinetic energy regenerative energy technology, through which the energy is recovered and supplemented to the battery, further improving the system efficiency and truck life. The annual comprehensive use cost of electric truck is only 23.2% of the internal combustion truck.

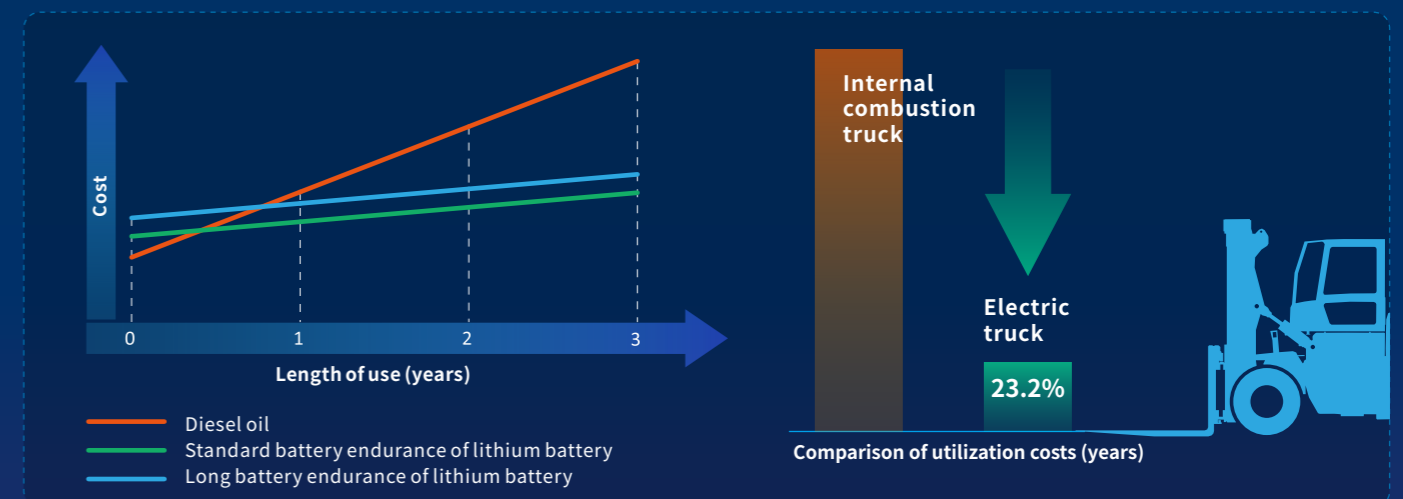

\* Due to the differences in working conditions, the fluctuation of electricity price and oil price, the data will fluctuate also, so the above data is for reference only.

# TECHNICAL PARAMETERS

TECHNICAL PARAMETERS								
Characteristics								
1.1	Model		CPD200	CPD250	CPD280	CPD300	CPD320	CPD350
1.2	Configuration name		A19LLIG2-12					
1.3	Rated capacity	kg	20000	25000	28000	30000	32000	35000
1.4	Load center distance	L1	mm 1200					
1.5	Lifting height (standard)	H3	mm 4000					
1.6	Mast tilt angle (forward/backward)	$\alpha/\beta$	deg 6/10					
1.7	Wheelbase	L2	mm 4250		mm 4650			
1.8	Tread front/rear	W1/W2	mm 2200/2510		mm 2490/2440			
1.9	Overhang(front/rear)	L3/L4	mm 1102.5/990		mm 1160/990			
1.10	Overall width	W	mm 3080		mm 3480			
1.11	Overall length (with fork)	L	mm 8782.5/6342.5		mm 9242/6802			
1.12	Overall height (cab/mast/max. height,extended)	H4/H/H1	mm 3795/3995/5995		mm 3805/4120/6120			
1.13	Minimum distance across fork-arms(mast)	H2	mm 280		mm 275			
1.14	Parking brake, laden/unladen		% 15/20		% 15/20			
1.15	Minimum turning radius (inside/outside)	R1/R2	mm 5920		mm 6400			
1.16	Fork size:length x width x thickness	l/e/s	mm 2440×250×112		mm 2440×300×115		mm 2440×300×120	
1.17	Fork adjustment range (outside of fork)	W3	mm 820-2700		mm 920-2850			
1.18	Maximum travel speed (laden/unladen)	km/h	24/25		24/26			
1.19	Maximum lift speed (laden/unladen)	mm/s	380/400		330/350		290/300	
1.20	Max. drawbar pull (laden/unladen)	KN	170		125			
1.21	Gradeability (laden/unladen)	%	20/25		15/25			
1.22	Total weight	kg	36000	37500	41000	41900	43700	45700
1.23	Tyres	Tyre size, front	14.00-24-28PR		16.00-25-36PR			
1.24		Tyre size, rear	14.00-24-28PR		16.00-25-36PR			
Motor								
2.1	Driving motor powering	kW	171					
2.2	Pump motor rated power	kW	90×2					
Drive axle								
3.1	Braking mode		Wet brake					
lithium								
4.1	Type		lithium iron phosphate battery					
4.2	rated voltage	V	608					
4.3	Battery capacity (standard/optional)	Kwh	210/315					

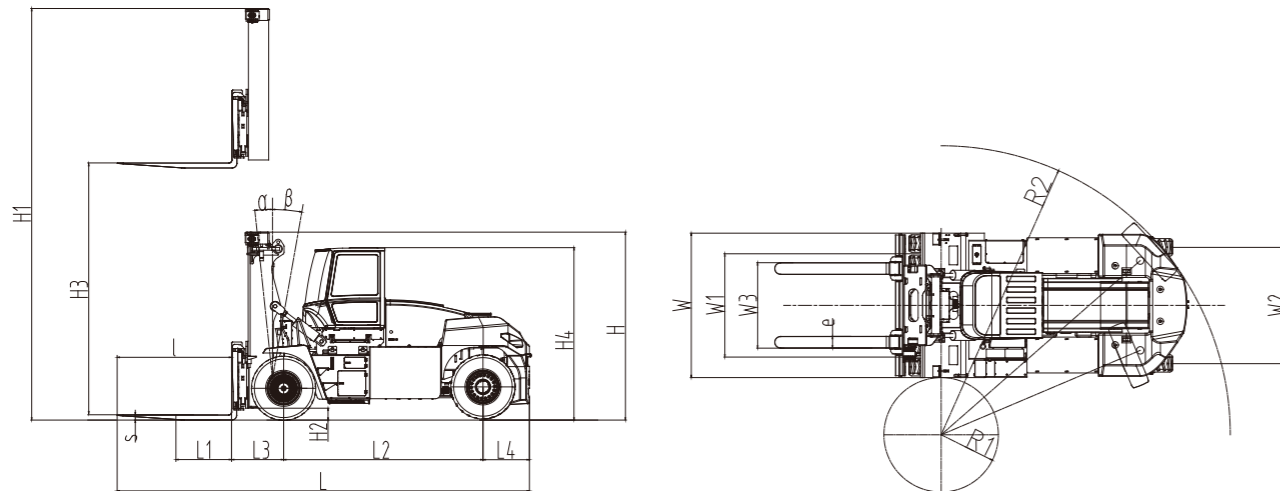

CPD200-250 NORMAL MAST					
Mast type	Maximum lifting height (mm)	Mast height(lowered) (mm)	Maximum mast height (mm)	Tilt angle (front/rear) ( $\alpha/\beta$ )(°)	Remarks
M400	4000	3995	5995	6/10	Standard Type
M450	4500	4245	6495	6/10	
M500	5000	4495	6995	6/10	
M550	5500	4745	7495	6/10	
M600	6000	4995	7995	6/10	
M650	6500	5245	8495	6/10	
M700	7000	5495	8995	6/10	
M750	7500	5745	9495	6/10	
M800	8000	5995	9995	6/10	

CPD280-350 NORMAL MAST					
	Maximum lifting height (mm)	Mast height(lowered) (mm)	Maximum mast height (mm)	Tilt angle (front/rear) ( $\alpha/\beta$ )(°)	Remarks
M400	4000	4120	6120	6/10	Standard Type
M450	4500	4370	6620	6/10	
M500	5000	4620	7120	6/10	
M550	5500	4870	7620	6/10	
M600	6000	5120	8120	6/10	
M650	6500	5370	8620	6/10	
M700	7000	5620	9120	6/10	
M750	7500	5870	9620	6/10	
M800	8000	6120	10120	6/10	

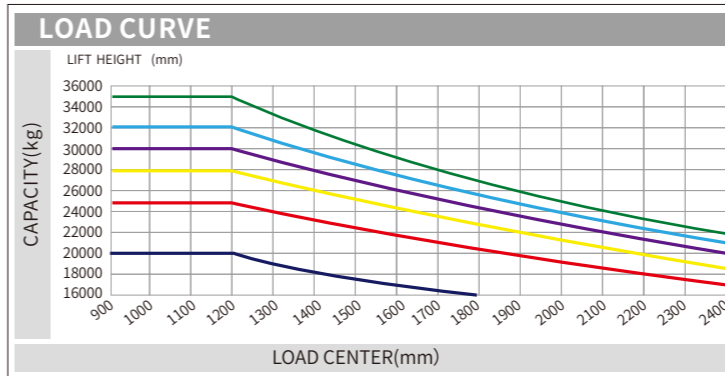

- 20T
- 25T
- 28T
- 30T
- 32T
- 35T

Note:  
Load center is measured from the fork front. A standard load center point refers to the center of a cubic of side length of 2400mm. When gantry tilts forward, the bearing capacity will reduce in case of use of non-standard fork or loading a load exceeding the normal width. Load curve tells you bearing capacity of various load centers in time.

## HELI INTELLIGENT FLEET MANAGEMENT SYSTEM

- Truck positioning
- Remote diagnostics
- Remote monitoring
- Maintenance Tips
- Statistical reports
- Truck management
- Identification (optional)
- Weighing management (optional)

