

HELI

www.heliforklift.net

HELI

45 t

**G2 series
Lithium Battery
Reach Stacker**

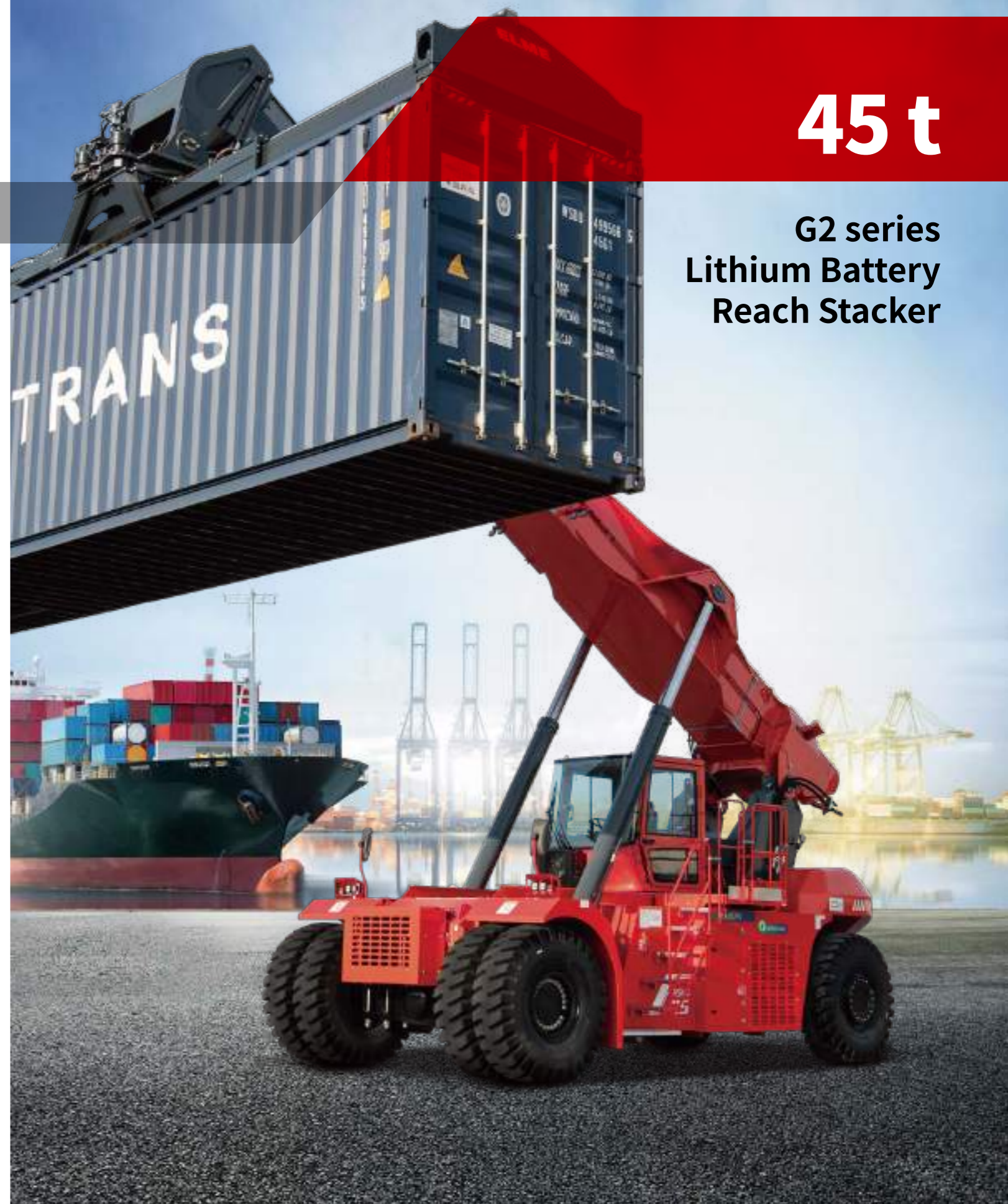

ANHUI HELI CO., LTD.

Add / No.668, FangXing Road, Hefei, China

Fax / +86-551-63639966

Tel / +86-551-63639068(America); 63639258(Europe);
63639358(Asia); 63662105(Africa & Middle East)



LinkedIn



YouTube



Facebook

Design&Print:Fokeli Printing / 20241121

* Our products are subject to improvements and changes without notice.

*With more than 60 years
of Heli technical precipitation*

HELI collaborates with the
strengths of others and creates
high-quality products.



Heli 45t electric reach stacker can be widely used in enterprises, stations, ports, docks, cabins etc., for oversized cargo handling and some types of empty container handling and stacking.

A

CHARACTERISTIC

1

LONG BATTERY ENDUREANCE

- Compatible with new energy vehicle charging pile and dual charging port as standard.
- The standard battery can working more than 8 hours under normal conditions, the standard battery can meet the normal working conditions of more than 8 hours, using 300KW charging pile and double gun charging 1.5 hours can be full charged. According to customer demands, up to 521kWh lithium-ion battery optional.



- Developed based on the IC truck platform, mature and reliable.
- Equipped with the mainstream permanent magnet synchronous motor, with the advantages of high efficiency, quick response, low failure rate and energy saving etc.
- The motor and controller adopt water cooling to ensure superior working condition.



- Adopt the world famous brand ELME original imported spreader, stable performance, reliable quality.
- Imported kessler brand drive axle, wet brake, dustproof and waterproof, maintenance-free.
- Excellent braking performance to meet the requirements of long time and heavy working conditions.
- High axle housing strength, high transfer efficiency and accuracy, stability and reliability.

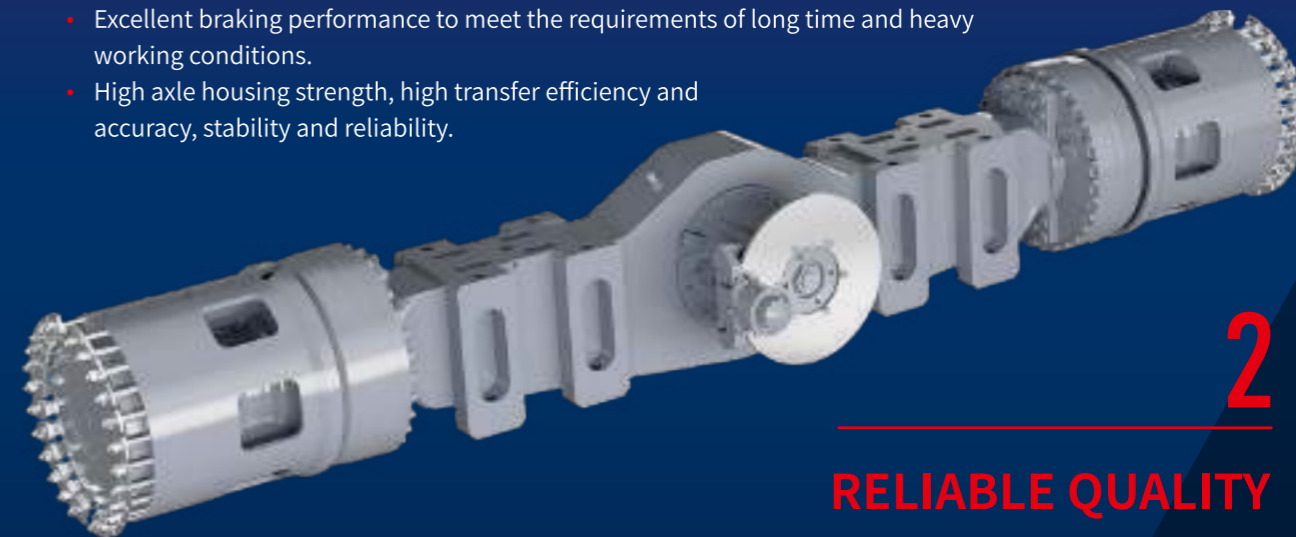

2

RELIABLE QUALITY

3

INTELLIGENT SAFETY

EIGHT ASPECTS OF SECURITY

- The truck high voltage line has insulation online monitoring function,combined with intelligent fire protection system,real-time monitoring of truck status can be achieved;
- High protection level(IP67) high voltage electrical components and intelligent temperature management system meet the outdoor all-weather work needs.

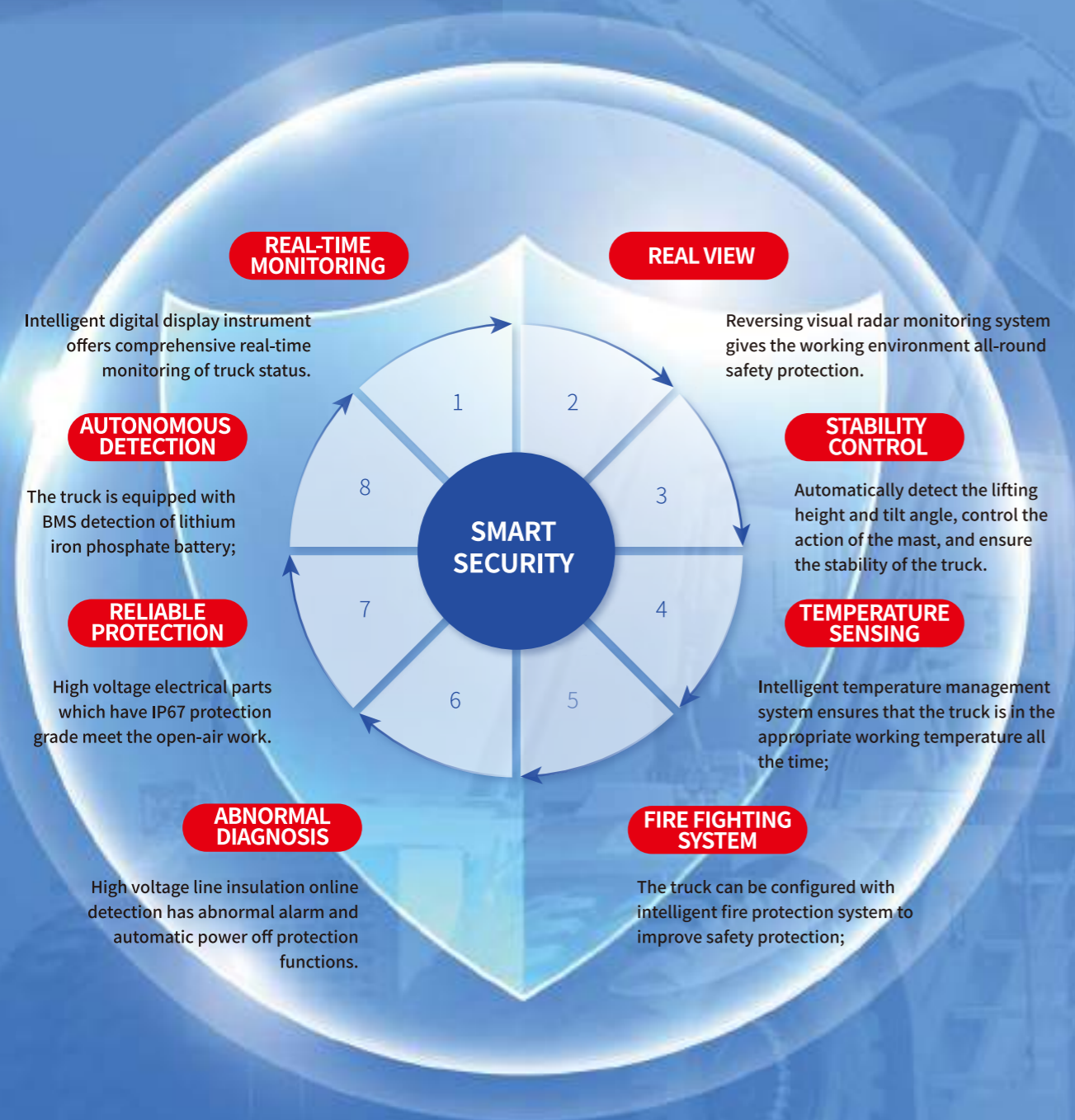

Rich instrument display content and human-computer interaction interface achieves timely acquisition of truck status, ensuring safe driving, stable operation.



The control panel is equipped with USB charging interface, radio with input port and support SD card, sunshade and bottle holder, etc., to provide drivers with a full range of "passenger vehicle" comfortable experience.

4

COMFORTABLE AND ECO-FRIENDLY

A RELAXED DRIVING EXPERIENCE FOR CUSTOMERS

- Fully closed sliding cab, reduce the noise transmission of the truck.
- Flow amplification technology, full hydraulic power steering, steering operation is light and flexible.
- Standard configuration of heating and cooling dual high-pressure electric split air conditioning offers high air conditioning energy utilization. The air duct is the front and the lower part, giving the driver a comfortable operating environment.



TECHNICAL PARAMETERS **B**

5 ECONOMIC

According to the calculation of 8 hours a day, the annual comprehensive use cost of electric truck is 17.5% of the IC truck, and the cost can be saved by 2.23 million RMB in 5 years. It can reduce carbon emissions by 180 tons per year.

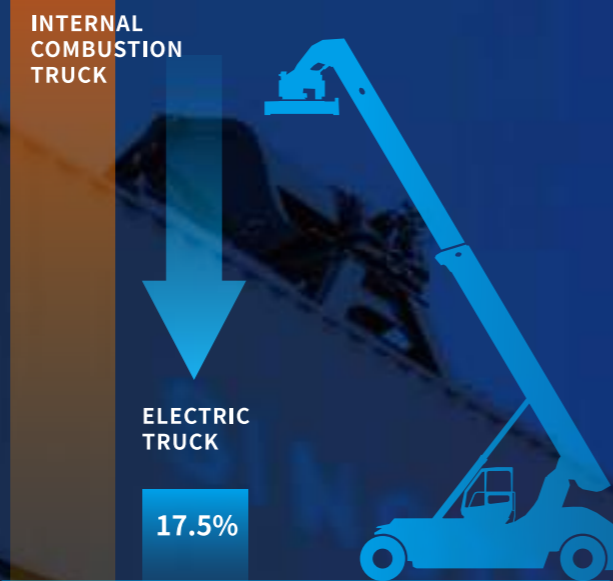

COMPARISON OF USING COSTS (ANNUAL)



1年后节省费用44.6万

5年后节省费用223万

TECHNICAL PARAMETERS		Electric reach stacker	
1.1	model	RSHD4527-A19LLiG2	RSHD4531-A19LLiG2
1.2	capacity (first row/second row/third row)	吨	45000/27000/15000
1.3	Lifting container specifications	ft	20/40/45
1.4	Maximum lifting speed (unload/load)	mm/s	420/280
1.5	Lowering speed (unload/load)	mm/s	360/360
1.6	Maximum travelling speed (unload/load)	Km/h	21/19
1.7	Maximum gradeability	%	15
1.8	overall length (including accessories)	mm	11300x4148x4754
1.9	wheelbas	mm	6000
1.10	Wheel distance (front/rear)	mm	3030/2838
1.11	model	EIME 817 INN	
1.12	side shift	mm	+800~-800
1.13	rotate	mm	-105~+195
1.14	reach stacker weight	kg	72000
1.15	battery type	LFP	
1.16	battery capacity	kWh	422.9 as standard, 507 optional
1.17	Charging time (300KW charger)	min	90

FORMAL SIZE

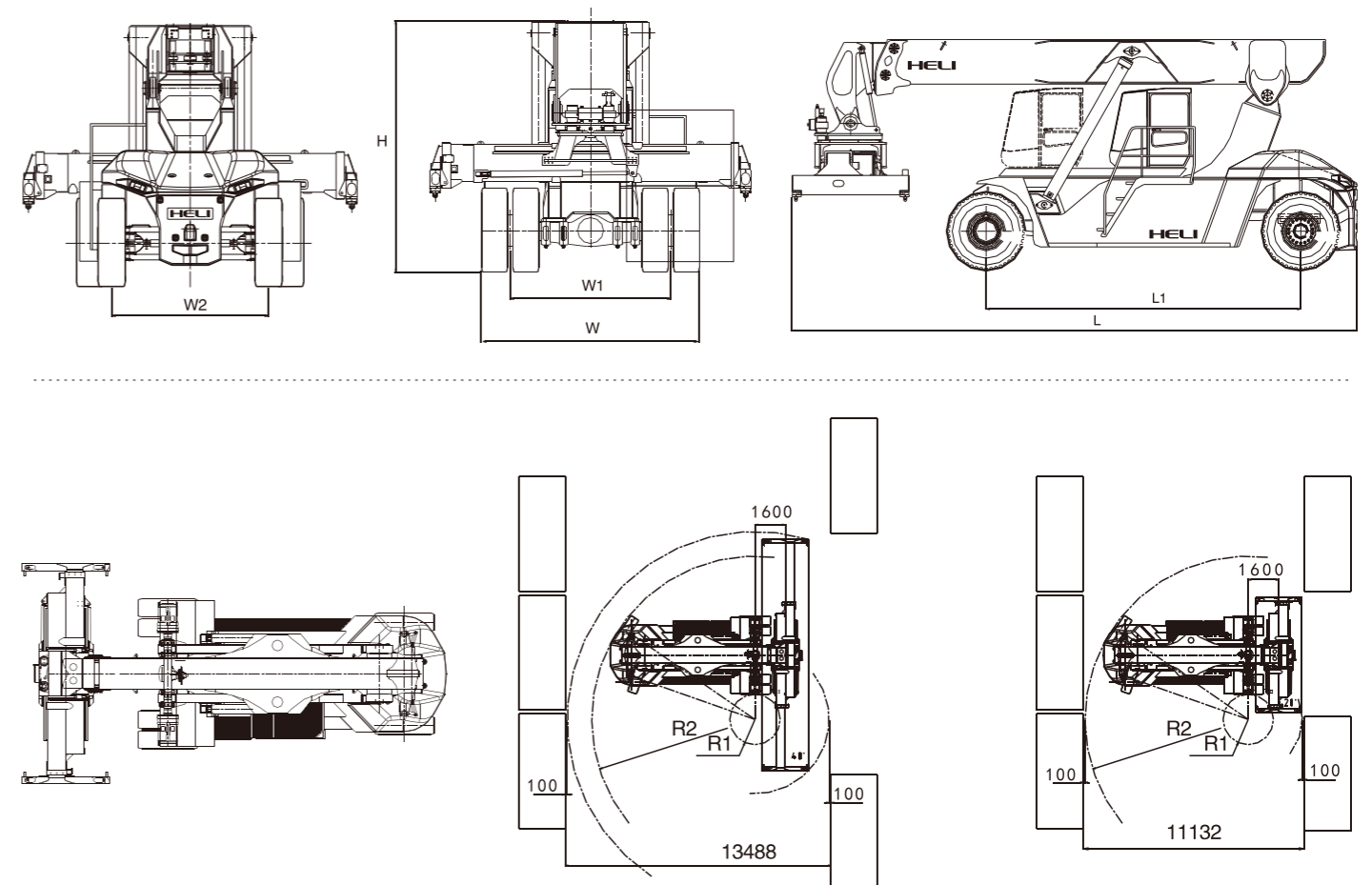

LOADING DIAGRAM

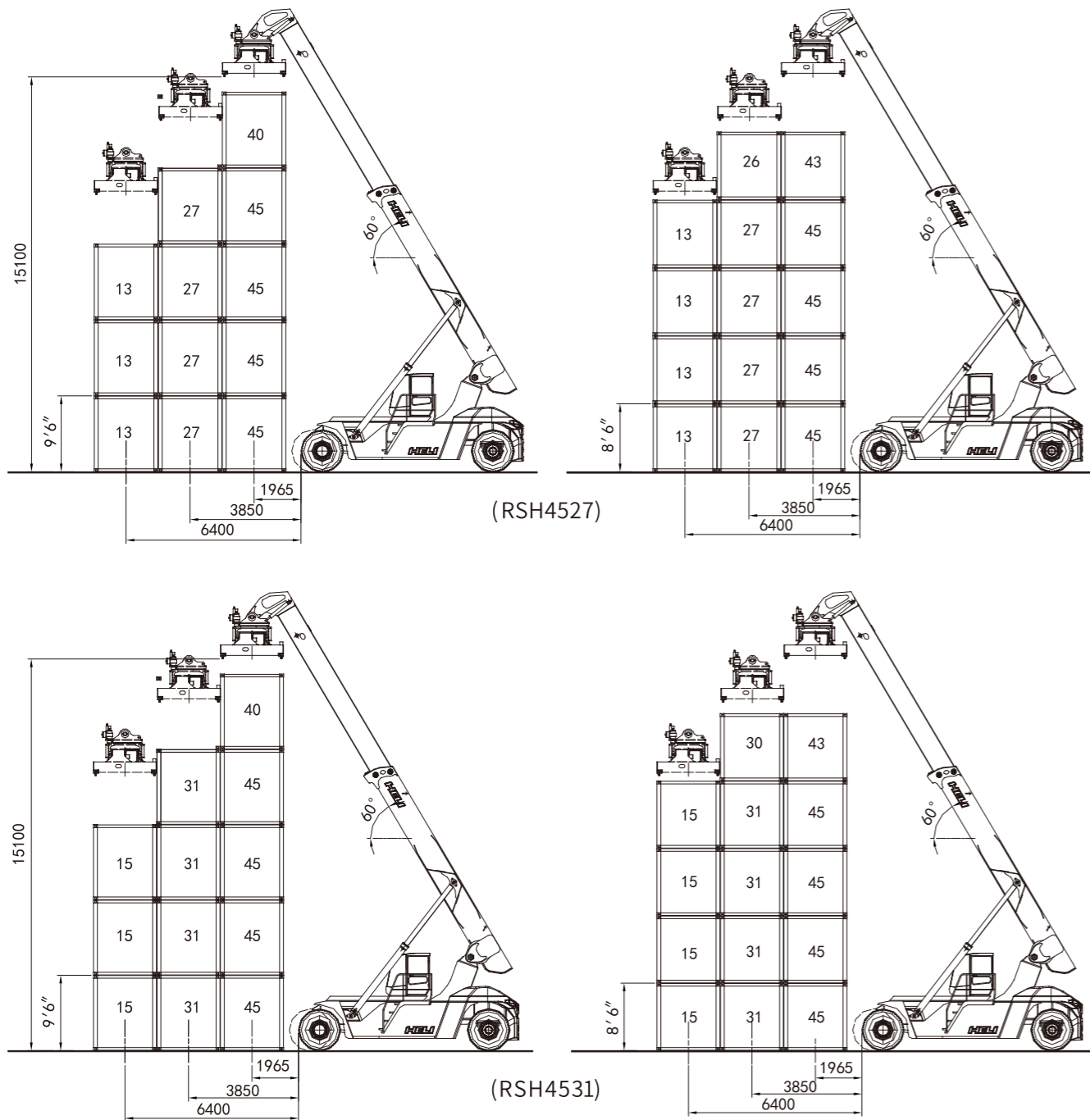

Standard configuration

	Characteristic	Standard configuration
1	Container reach stacker series	45t electric reach stacker
2	Energy storage device	Lithium-ion battery(catl cell)
3	Traction motor and controller	Adopt water cooling for heat dissipation
4	Pump motor and controller	Adopt water cooling for heat dissipation
5	Drive axle	German kessler d102 high-speed ratio drive axle
6	Hydraulic system	Electric proportional control with energy recovery
7	Spreader	Elme 817inn spreader
8	Controllersystem	Parker safety control communication system
9	Number of tyre	4 forward/2 backward
10	Type of tyre	Vacuum pneumatic tyre
11	Cab	Wide view cab
12	Air conditioner	Dual heating and cooling air conditioning
13	Working light	Led lighting system
14	Hydraulic oil heat dissipation	Independent liquid dispersion thermal system
15	Multimedia	Radio
16	Steering wheel	Knob
17	Steering machine	Adjustable direction machine
18	Seat	Full suspension seat
19	Safe channel for get on and off	Hollowed-out escalators on both sides
20	Astern safety	Astern video and radar
21	Lubrication maintenance	Central lubrication unit
22	Usb interface	1 usb port
23	Variable operating view	Self-locking electrically controlled hydraulic skid cab
24	Vehicle networking	Fics system

Option configuration

	Characteristic	Option configuration
1	Truck	Automatic centralized lubrication system for import configuration
		Automatic centralized lubrication system for domestic configuration
		Engine compartment fire protection system
		Imported Horse tire (vacuum tire)
2	Electrical system	Container handling statistics and printing system
		Intercom communication system
		Tire pressure monitoring
3	spreader	Steel pipe clamp
		Lifting hook
		Container tipping spreader
4	Seat options	Log clamp
		With safety switch

HELI INTELLIGENT FLEET MANAGEMENT SYSTEM

- Truck positioning
- Remote diagnostics
- Remote monitoring
- Maintenance Tips
- Statistical reports
- Truck management
- Identification (optional)
- Weighing management (optional)

